

ANT280 Temperature Transmitter

Product Description

This temperature transmitter uses industrial platinum resistance thermometer which usually uses with display, recorder and controller. It could measure the temperature directly from the media surface of liquid, steam and solid in the range of $-50^{\circ}\text{C} \sim 500^{\circ}\text{C}$. And it has explosion proof.

Feature

- Small size, easy to install;
- High stability, Transmitter could be touch the media directly;
- Stainless steel material , corrosion resistant;
- Customized.



Specification

Type	Temperature Range	Platinum Thermistor	Tolerance parameters Δt $^{\circ}\text{C}$
P-shape heat resistance	$-30^{\circ}\text{C} \sim 300^{\circ}\text{C}$	Pt100	Grade A ($-30^{\circ}\text{C} \sim 300^{\circ}\text{C}$) Allowable $\pm (0.15 + 0.002 t)$
P-shape heat resistance	$-50^{\circ}\text{C} \sim 500^{\circ}\text{C}$	Pt100	Grade B ($-50^{\circ}\text{C} \sim 500^{\circ}\text{C}$) Allowable $\pm (0.30 + 0.005 t)$

Shape structure

Unit: mm;

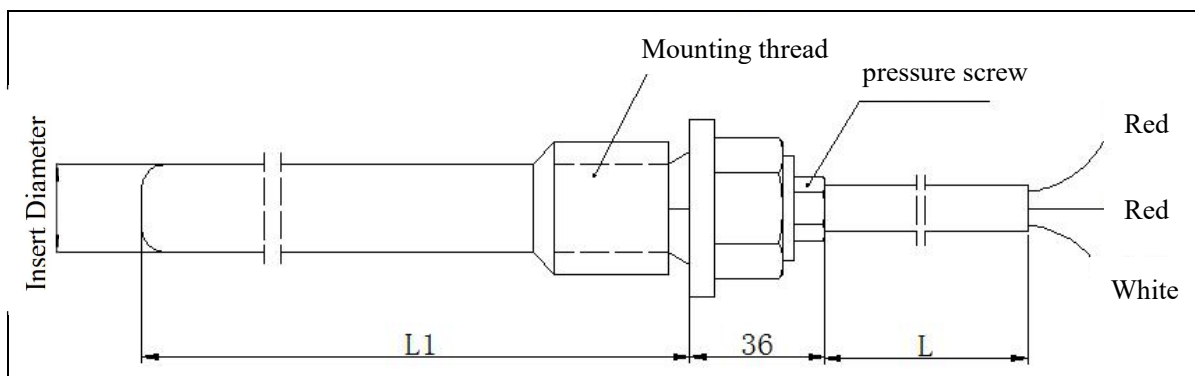

L-Cable type

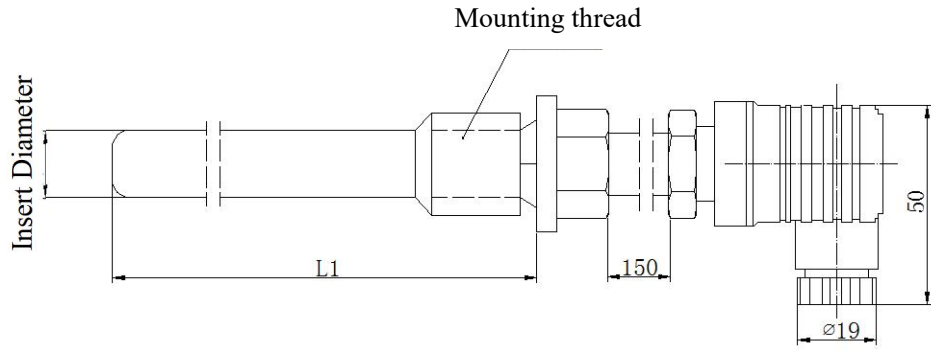

H-Hirschman Connector

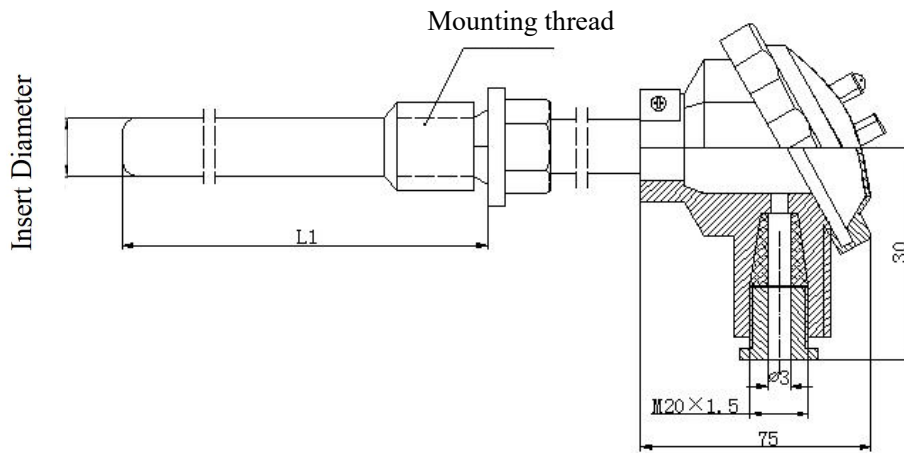

F-Weather Proof Connector

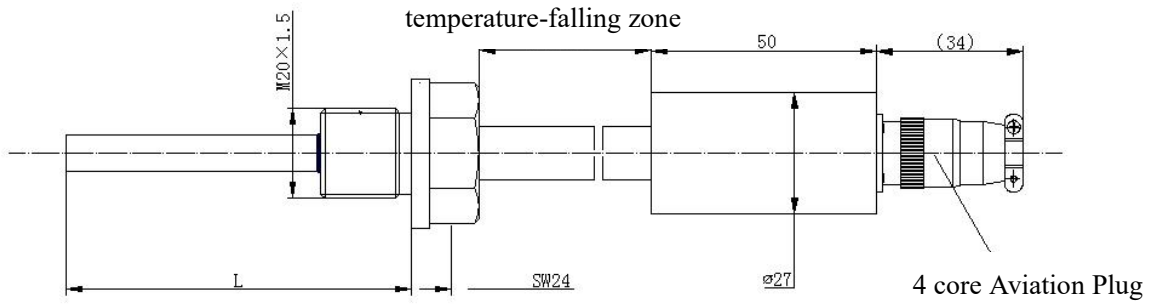

K-4 cores

Electrical Connections

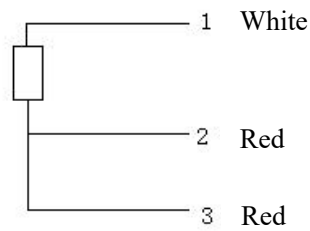

L-Cable

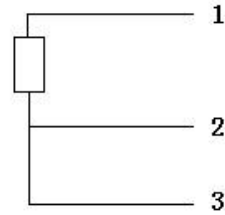
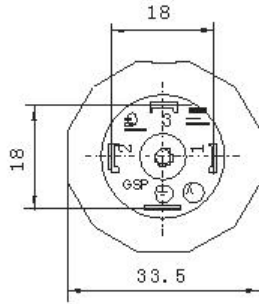

H- Hirschman Connector

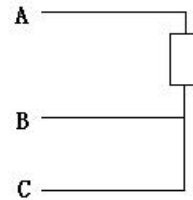
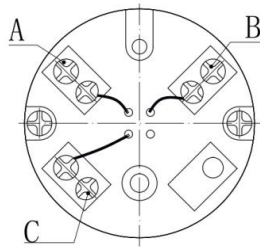

F-Weather Proof Connector (single)

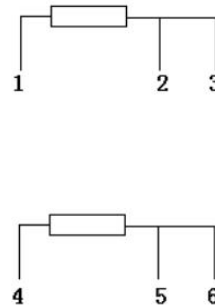
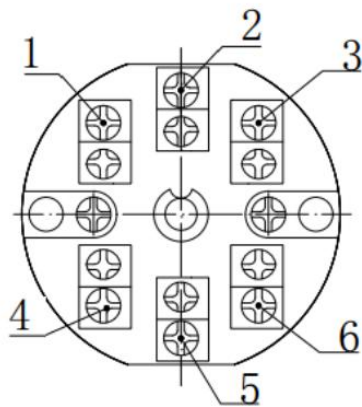

Waterproof Terminal Box (double)

Selection Guide

ANT280	Temperature Transmitter (ANT280-Single Platinum Thermistor Temperature Sensor; ANT280D-Double Platinum Thermistor Temperature Sensor)	
Insert Depth	L1	Depth Specification (eg: XXXXmm) ; include the length of fix screw
Installation	M	Screw thread M27×2, length 32mm

	G	Screw thread G1/2, length 20mm
	C	Screw thread M20×1.5, length 18mm
	T	Remark as Special thread
External Diameter of Protective Tube (Typical), Unit: mm	6	φ 6mm
	8	φ 8mm
	10	φ 10mm
	12	φ 12mm
	612	Inner Tube φ 6, Outer Tube φ 12 (double pipe)
	816	Inner Tube φ 8, Outer Tube φ 16 (double pipe)
Electronic Connector	L	Cable (Default length 200mm)
	H	Hirschman
	F	Weather Proof Connector (double)
	K	4 core Aviation Plug
Range		(X~Y) °C, Y means URL and LRL, Unit:°C。
Item No. :	eg: ANT-100-C-8-H (-20~80°C)	

Selection noted:

Eg: ANT280-150MΦ 10H : Platinum thermistor=Pt100、Insert depth=150mm、Screw thread= M27×2、External Diameter=Φ 10mm、Electronic Connector= Hirschman.